

**DATAcap MODEL 3261 SSI TO RS232C PRINTER CONTROLLER
(WITH AT&T® SSI PRINTER SUPPORT - VERSION 6.07 OR LATER)**

GENERAL DESCRIPTION

The DATAcap model 3261 printer controller is a self contained SSI (AT&T® 56K baud Standard Serial Interface) to asynchronous RS232C serial or SSI printer interface adapter. It is intended for use as a general purpose RS232C serial or SSI printer controller for an AT&T® 6544 or equivalent type cluster controller running Generic 3.X.X , 4.X.X or later system software.

The 3261 directly connects to an AT&T® 6544 or equivalent cluster controller SSI printer port (C-CARD). The cluster controller printer port can be configured as any printer type P1 through P8 (including P5 type - 6571 printer). The output of the 3261 drives all RS232C serial printers as well as the model 40/45 SSI line printer or AP201 type SSI matrix printer, without the need to reconfigure the cluster controller printer P-type (P1 - P8). When the cluster controller device port is configured as a P4 type (AT&T® 5310/20 RS232C ANSI 3.64 printer), the 3261 passes all ANSI 3.64 escape sequences from the host. For all other P-type printer configurations, the 3261 suppresses all ANSI 3.64 escape sequences. The RS232C serial printers are required to perform only the basic functions of carriage return, line feed, and form feed. During Print Screen or Print Local, escape sequences are always suppressed. The RS232C printer speed can be optioned for 2400, 9600, 19200, or 38400 baud. The RS232C printer data flow control can be optioned for Xon/Xoff or hardware Busy. The 3261 supports SNA/SDLC and Bisync host protocols as either an LU1 (Logical Unit) or LU3 type printer and in addition, it supports asynchronous host protocols. The adapter is packaged in a 6X9X1¼ inch molded enclosure and is powered by a UL listed class II 115 volt AC 60 HZ wall mounted 10 volt AC transformer.

BASIC FEATURES

- * • Unattended operation - automatic recovery from printer out of service (no alarm resetting)
- * • Built-in 16,000 character print spooler for faster printer throughput (can be disabled)
- * • Truncates trailing SPACE characters to printer for faster data transfer
 - Supports AT&T® M40/45 SSI line printers or AP201 type SSI matrix printers (Version 6.07 or later)
- * • Provides simultaneous RS232C monitoring output when driving SSI printers (Version 6.07 or later)
- * • Supports all RS232C serial printers with any Generic 3.X.X system software with or without an "X" card as well as Generic 4.X.X or later system software - Hardware Busy or Xon/Xoff protocol
- * • Automatically emulates P1 through P8 type printers, including the 6571 SSI printer - reconfiguring the cluster controller is not necessary for either an RS232C or SSI printer
- * • RS232C Interface Strap Options for DCE/DTE configuration (use standard 1 to 1 RS232C cable)
- * • Suppresses Form Feed if printer is already at Top of Form (same as AT&T® M40/45 printers)
- * • Page form length control resides in printer for better application software compatibility
- * • Option for Form Feed at end of SCS print (SNA protocol only) if printer is not at Top of Form
- * • Suppresses ANSI 3.64 Escape Sequences to printer, including asynchronous Print On-Line mode, except if controller port is configured as a P4 type (AT&T® 5310/20 type printer)
- * • EBCDIC font option - EBCDIC Pipe Symbol (hex 4F) prints as '!' on ASCII printer instead of ']'
- * • EBCDIC 'Escape' character option - EBCDIC 'ø' (hex 4A) prints as ASCII Escape (hex 1B) ①
 - Generates Carriage Return - Line Feed on New Line character
 - RS232C and SSI status indicator lamps
 - Prints cluster controller printer device port options during Local Test mode
 - Self Test diagnostics with printout or front panel lamp display of option settings
 - Supports the following cluster controller device port options:
 - FF on fixed line message, FF on NL/EM message, Suppress NL at right margin, FF at end of Print Local, Print Screen, or Print On-Line, and CR on EM after FF

* Features currently not supported by AT&T® 6561 type printer controller ① Version 5.12 or later

DATAcap, Inc.

11558 Sorrento Valley Road - Building 4 • San Diego, California 92121-1312 • (619) 455-5431 • FAX (619) 481-6038

TECHNICAL SPECIFICATIONS

SSI INTERFACE TO 6544 TYPE CLUSTER CONTROLLER - PORT A

Emulation: AT&T® 6561/71 printer controller with Generic 3.X.X or later system software
 Host Protocol: SNA/SDLC and Bisync as LU1 or LU3 type printer, or Asynchronous
 Data Format: 18 bits - start bit + control bit + 8 bit SSI high byte + 8 bit SSI low byte
 SSI Signaling: 2.5 ± 1 Volt peak to peak transformer isolated at 56,000 baud
 Connector: Standard RJ45 8 pin modular SSI connector (Port A)
 Cable Length: 5000 feet maximum using two twisted pair telephone cable

RS232C SERIAL PRINTER INTERFACE OR MONITORING PORT FOR SSI PRINTER

Emulation: Generic RS232C (P1 - P8 except P4 type) or ANSI 3.64 RS232C (P4 type)
 Speed: 2400, 9600, 19200, or 38400 (4800 when monitoring SSI printer) baud
 Protocol: Xon/Xoff (when monitoring SSI printer) or Ready/Busy data flow control
 Data Format: 7 bits + EVEN parity or 8 bits + no parity (bit 8 = SPACE)
 Connector: RS232C 25 pin female DB-type - configurable as DCE/DTE (factory set DCE)

SSI PRINTER INTERFACE - PORT B (Version 6.07 or later)

Emulation: Model 40/45 SSI line printer or AP201 type SSI matrix printer
 SSI Signaling: 2.5 ± 1 Volt peak to peak transformer isolated at 56,000 baud
 Protocol: SSI character at a time protocol (with simultaneous RS232C monitoring)
 Data Format: 7 bits + EVEN parity or 8 bits + no parity (bit 8 = SPACE)
 Connector: Standard RJ45 8 pin modular SSI connector (Port B)
 Cable length: 2000 feet maximum using two twisted pair telephone cable

PHYSICAL SIZE 6 X 9 X 1¼ inches

POWER UL listed class II 10 volts AC plug-in 115 volts 60 Hz transformer at less than 4 volt-amperes (3 BTU's per hour maximum)

TEMPERATURE 0 TO 50° C operating, -40 to 70° C storage

HUMIDITY 2% to 95% non-condensing

FRONT PANEL

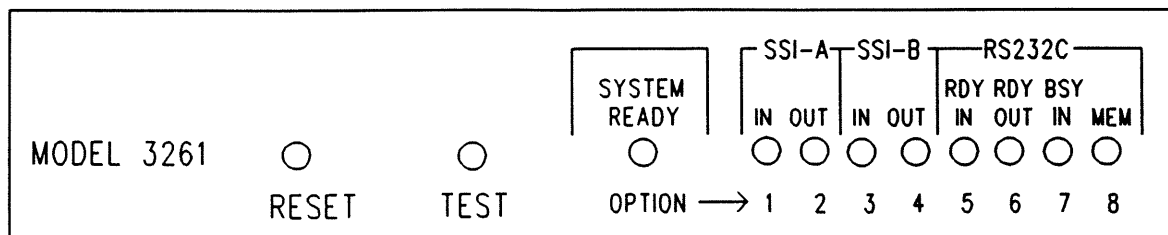

FIG.1

FRONT PANEL INDICATOR LAMPS

The model 3261 adapter has nine front panel indicator lamps that display the status of the SSI interface and the serial RS232C printer interface.

INDICATOR LAMP	DESCRIPTION
SSI-A IN:	<ul style="list-style-type: none"> - ON STEADY when the SSI input from attached cluster controller has clock present - BLINKING when SSI data is being received from cluster controller - OFF when the SSI input from attached cluster controller is not functioning
SSI-A OUT:	<ul style="list-style-type: none"> - ON STEADY when the SSI output from the 3261 is idle. - BLINKING when SSI data is being transmitted to the attached cluster controller - OFF when the 3261 is not functioning
SSI-B IN:	<ul style="list-style-type: none"> - ON STEADY when SSI input from attached SSI printer has clock present - BLINKING when SSI status is being received from SSI printer - OFF when no signal is being received from SSI printer
SSI-B OUT:	<ul style="list-style-type: none"> - ON STEADY when the 3261 is optioned for an SSI printer and no data is being sent to the printer - BLINKING when data is being sent to the SSI printer - OFF when the 3261 is optioned for an RS232C printer
SYSTEM READY:	<ul style="list-style-type: none"> - ON when the attached RS232C printer and the 3261 are both ready - OFF when the attached RS232C printer is Out of Service, the 3261 is not ready, or the cluster controller has removed the 3261 from service
RDY OUT:	<ul style="list-style-type: none"> - ON when normal operation of the 3261 - OFF when the 3261 is not functioning
RDY IN:	<ul style="list-style-type: none"> - ON when the attached RS232C printer is ready and on-line - OFF when the attached RS232C printer is off-line or out of paper (for Out of Service condition)
BSY IN:	<ul style="list-style-type: none"> - ON when the 3261 receives a Not Busy signal (for hardware busy protocol) from the RS232C printer - OFF when the 3261 receives a Busy signal (for hardware busy protocol) from the RS232C printer
MEM:	<ul style="list-style-type: none"> - ON STEADY when the 3261 has data in memory and is sending to the printer - BLINKING when the 3261 has data in memory and is not sending to the RS232C printer (3261 received a Busy or Xoff flow control character from RS232C printer) - OFF when the 3261 has no data to send to the RS232C printer

FRONT PANEL PUSH BUTTON SWITCHES

The model 3261 adapter has two front panel push button switches.

Depressing the **RESET** button initializes the 3261 and requests a new down line load from the cluster controller.

Depressing the **TEST** button for less than 2 seconds causes the Xon/Xoff data flow control to manually resume (Xon). This feature is used when the 3261 receives an Xoff character without an Xon character (with Xon/Xoff flow control option only).

Depressing the **TEST** button for longer than 3 seconds will send a Local Test report to the printer, provided the 3261 is on-line (SYSTEM READY) with the cluster controller. The report shows the printer device port options from the cluster controller as well as the software version of the 3261.

LOCAL TEST

Depressing the TEST button for greater than 3 seconds after the 3261 is down line loaded from the 6544 type cluster controller and the 3261 is ready (SYSTEM READY lamp ON), will send a local test message to the printer as shown below-

LOCAL TEST PRINTER TYPE P4
(ANSI 3.64 PRINTER)

COM PORT NAME : BISYNC-2
STATION ADDRESS: 31 Hex
COM PORT NUMBER: 02 Dec
DEV/LU NUMBER : 008 Dec
DEV PORT NUMBER: 07 Dec
PRINTER MODE : BOTH HOST AND LOCAL PRINTER

FF AT END OF PL, PS, POL : Y
FF ON FIXED LINE MESSAGE : N
SUPPRESS NL AT RT-MARGIN : N
CR ON EM AFTER FF : N
FF ON NL/EM MESSAGE : N

Model 3261 Software Version Number: 6.08
Copyright 1992.

Note: Successive invoking of the above LOCAL TEST mode will print additional COM port parameters if multi-host printer sharing is optioned in the cluster controller.

POWER ON TEST

The model 3261 performs a hardware self test during POWER ON or after depressing the RESET button. Immediately after Power On or Reset, the nine LED lamps pulse ON for about a half second followed by approximately 4 seconds of all LED lamps OFF. The success or failure of the Power On Self Test is indicated by individual lamps pulsing three times (Pass) or none (Failure) before all nine LED lamps pulse ON again at the completion of the hardware test.

- | | |
|---------------------|---|
| Program EPROM Test | - MEM Lamp (8) pulses three times to indicate EPROM Test Passed |
| Data RAM Test | - BSY IN Lamp (7) pulses three times to indicate Data RAM test Passed |
| Main RS232C Test | - RDY OUT Lamp (6) pulses three times to indicates the main RS232C loopback test passed. To perform this test, the female 25 pin connector must be jumpered between pins 2-3, 4-5-11, and 8-20. |
| AUX RS232C Test | - RDY IN Lamp (5) pulses three times to indicate the AUX RS232C loopback test passed. To perform this test, the male 9 pin connector must be jumpered between pins 2-3 and 4-5. |
| SSI-A Internal Test | - SSI-A IN Lamp (1) pulses three times to indicate the SSI-A port internal loopback passed. To perform this test, the external SSI-A cable must be unplugged. |
| SSI-A External Test | - SSI-A OUT Lamp (2) pulse three times to indicate the SSI-A port external loopback passed. To perform this test, the SSI-A RJ45 connector must be jumpered between pins 1-3 and 2-6 with a loopback cable. |
| SSI-B Internal Test | - SSI-B IN Lamp (3) pulses three times to indicate the SSI-B port internal loopback passed. To perform this test, the external SSI-B cable must be unplugged. |
| SSI-B External Test | - SSI-B OUT Lamp (4) pulse three times to indicate the SSI-B port external loopback passed. To perform this test, the SSI-A RJ45 connector must be jumpered between pins 1-3 and 2-6 with a loopback cable. |

Note: Numbers in parenthesis indicate front panel Option numbers marked below lamps

3261 INSTALLATION SWITCH OPTIONS

OPT #	OPTION DESCRIPTION	DIP SWITCH SETTINGS				
		SW1-1	SW1-2	SW1-3	SW1-4	SW1-5
PRINTER SPEED OPTIONS						
1A	2400 BAUD	-	OFF	OFF	-	-
◆1B	9600 BAUD	-	ON	OFF	-	-
1C	19200 BAUD	-	OFF	ON	-	-
1D	38400 BAUD (4800 IF OPTION [4N] IS SET)	-	ON	ON	-	-
PRINTER PARITY OPTIONS						
2A	7 BITS + EVEN PARITY	OFF	-	-	-	-
◆2B	8 BITS + NO PARITY (BIT 8 = SPACE)	ON	-	-	-	-
PRINT SPOOLER OPTION						
◆3A	ENABLE 16K PRINT SPOOLER	-	-	-	ON	-
3B	DISABLE 16K PRINT SPOOLER	-	-	-	OFF	-

◆ FACTORY SETTINGS

RS232C INTERFACE STRAP OPTIONS

The RS232C Interface Strap Options must be properly configured in addition to the Installation Dip Switch Options. The Interface Strap Options permit the 3261 to emulate Data Terminal Equipment (DTE) or Data Communication Equipment (DCE) without the need for special cross-over RS232C cabling. The model 3261 is factory shipped as shown in FIG. 3. This arrangement emulates a DCE, allowing direct cabling to RS232C printers or other DTE equipment. The arrangement shown in FIG. 4 is recommended for HP LaserJet operation or other printers that toggle Data Terminal Ready (DTR - pin 20) on printer BUSY. FIG. 5 shows a typical DTE arrangement for direct cabling to a modem or DCE. The FIG. 3 arrangement is equivalent to the earlier versions of the model 3261. The RS232C Interface Strap Options are located next to the RS232C 25 pin connector as shown in FIG. 2.

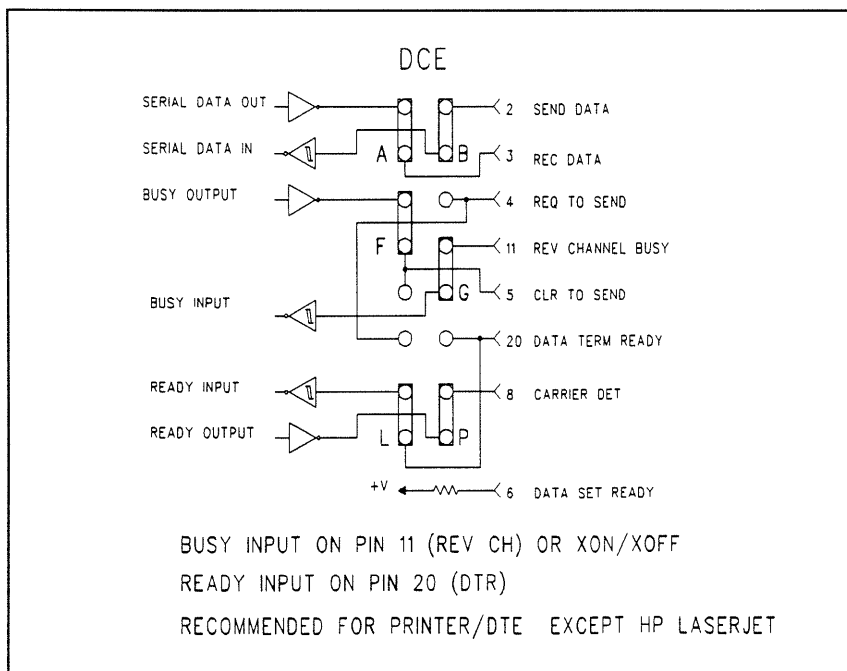

FIG. 3 (Factory Setting OPTION [4A] INTERFACE STRAPS)

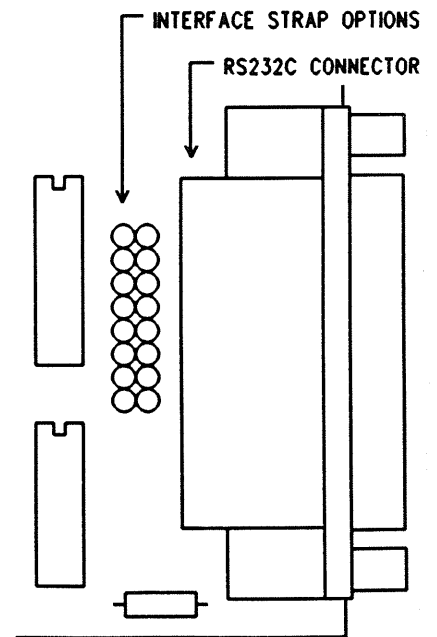

FIG. 2

HP LASERJET DCE ARRANGEMENT EXAMPLE (REFER TO PAGE 9)

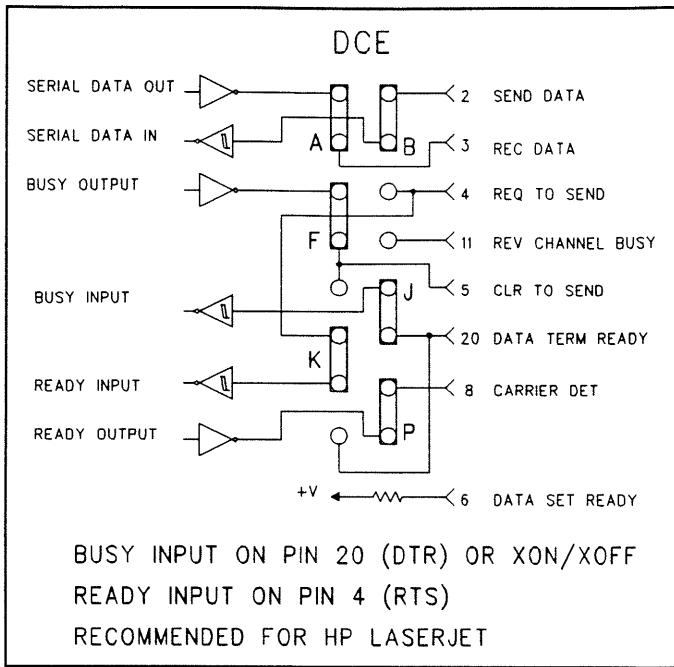

FIG. 4 (OPTION [4C] INTERFACE STRAPS)

MODEM DTE ARRANGEMENT EXAMPLE (REFER TO PAGE 9)

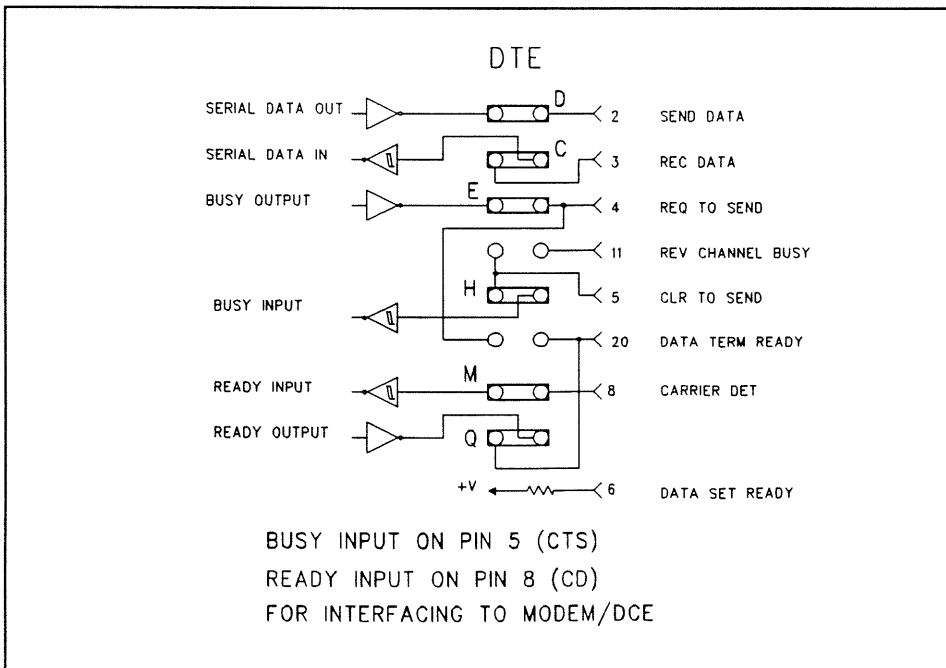

FIG. 5 (OPTION [4P] OR [4R] INTERFACE STRAPS)

3261 INSTALLATION SWITCH OPTIONS - CHOOSE ONE (CONTINUED)

OPT #	OPTION DESCRIPTION	DIP SWITCH SETTINGS			INTERFACE STRAPS (SEE BELOW)
		SW1-6	SW1-7	SW1-8	
PRINTER PROTOCOL (DCE - MODEM EMULATION)					
XON/XOFF BUSY FLOW CONTROL					
OUT OF SERVICE CONDITION:					
◆4A	DTR OFF - PIN 20 OR BUSY TIMEOUT ①	ON	ON	ON	A, B, F, G, L, P
4B	DTR OFF - PIN 20 OR BUSY TIMEOUT ②	ON	ON	OFF	A, B, F, G, L, P
4C	RTS OFF - PIN 4 OR BUSY TIMEOUT ①	ON	ON	ON	A, B, F, J, K, P
4D	RTS OFF - PIN 4 OR BUSY TIMEOUT ②	ON	ON	OFF	A, B, F, J, K, P
REV. CHANNEL (PIN 11) BUSY FLOW CONTROL					
OUT OF SERVICE CONDITION:					
4E	DTR OFF - PIN 20 OR BUSY TIMEOUT ①	ON	OFF	ON	A, B, F, G, L, P
4F	DTR OFF - PIN 20 ONLY	ON	OFF	OFF	A, B, F, G, L, P
4G	RTS OFF - PIN 4 OR BUSY TIMEOUT ①	ON	OFF	ON	A, B, F, J, K, P
4H	RTS OFF - PIN 4 ONLY	ON	OFF	OFF	A, B, F, J, K, P
DTR (PIN 20) BUSY FLOW CONTROL					
OUT OF SERVICE CONDITION:					
4J	RTS OFF - PIN 4 OR BUSY TIMEOUT ①	ON	OFF	ON	A, B, F, J, K, P
4K	RTS OFF - PIN 4 ONLY	ON	OFF	OFF	A, B, F, J, K, P
4L	BUSY TIMEOUT ① ONLY	OFF	OFF	ON	A, B, F, G, L, P
4M	IGNORES PRINTER OUT OF SERVICE	OFF	OFF	OFF	A, B, F, G, L, P
PRINTER PROTOCOL (40/45 OR AP201 SSI PRINTER)					
4N	USE SSI PORT B MODULAR CONNECTOR ③	OFF	ON	ON	A, B, F, G, L, P
PRINTER PROTOCOL (DTE - TERMINAL EMULATION)					
XON/XOFF BUSY FLOW CONTROL					
OUT OF SERVICE CONDITION:					
4P	CARRIER OFF - PIN 8 OR BUSY TIMEOUT ①	ON	ON	ON	C, D, E, H, M, Q
4R	CARRIER OFF - PIN 8 OR BUSY TIMEOUT ②	ON	ON	OFF	C, D, E, H, M, Q

◆ FACTORY SETTINGS

NOTES:

- ① BUSY TIMEOUT APPROX. 60 TO 90 SECONDS - CAUSES OUT OF SERVICE
- ② BUSY TIMEOUT APPROX. 60 TO 90 SECONDS - CAUSES AUTO XON RESUME
- ③ REQUIRES A DATAcap P/N 98-051M OR EQUIVALENT 8 PIN MODULAR TO 9 PIN MOLEX® SSI PRINTER CABLE. THE 25 PIN RS232C INTERFACE ALSO IMAGES THE SSI PRINTER DATA FOR MONITORING WITH AN RS232C RECEIVING DEVICE. THE RS232C MONITORING PROTOCOL IS ALWAYS XON/XOFF. THE BAUD RATE IS SET PER OPTION 1A, 1B, 1C, OR 1D AND THE PARITY IS SET PER OPTION 2A OR 2B ON PAGE 7. THE INTERFACE STRAP OPTIONS ARE SHOWN FOR A DCE ARRANGEMENT. **OPTION [4N] ONLY APPLIES TO 3261 VERSIONS 6.07 AND LATER.**

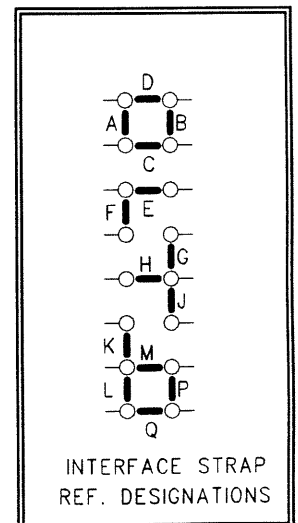

INTERFACE STRAP REF. DESIGNATIONS

3261 INSTALLATION SWITCH OPTIONS (CONTINUED)

OPT #	OPTION DESCRIPTION	DIP SWITCH SETTINGS							
		SW2-1	SW2-2	SW2-3	SW2-4	SW2-5	SW2-6	SW2-7	SW2-8
	OTHER OPTIONS								
◆5A	FORM FEED AT END OF SCS PRINT - OFF	-	-	-	-	-	-	-	OFF
5B	FORM FEED AT END OF SCS PRINT - ON	-	-	-	-	-	-	-	ON
◆6A	ASCII FONT: 'I' PRINTS AS 'J' ④	-	-	-	-	-	-	OFF	-
6B	EBCDIC FONT: 'I' PRINTS AS 'J' ④	-	-	-	-	-	-	ON	-
◆7A	GENERIC SOFTWARE 3.0.X - 3.3.X COMPATIBILITY					OFF	OFF		
7B	GENERIC SOFTWARE 4.X.X OR LATER COMPATIBILITY					-	ON		
7C	GENERIC SOFTWARE 3.4.X ⑤					ON	OFF		
◆ --	RESERVED	OFF	OFF	OFF	OFF	-	-	-	-

◆ FACTORY SETTINGS

NOTES:

④ EFFECTIVE FOR EBCDIC HOSTS ONLY:

ASCII FONT OPTION (SW2-7 = OFF) -

'I' (EBCDIC HEX 4F) PRINTS AS 'J' (ASCII HEX 5D)
 '¢' (EBCDIC HEX 4A) PRINTS AS '^' (ASCII HEX 5E)
 '→' (EBCDIC HEX 5F) PRINTS AS '[' (ASCII HEX 5B)

EBCDIC FONT OPTION (SW2-7 = ON) -

'I' (EBCDIC HEX 4F) PRINTS AS 'I' (ASCII HEX 7C)
 '¢' (EBCDIC HEX 4A) PRINTS AS 'ESC' (ASCII HEX 1B) ⑥
 '→' (EBCDIC HEX 5F) PRINTS AS '[' (ASCII HEX 5B)

⑤ Added at version 5.10 (032493)

⑥ Changed to 'ESCAPE' from '^' at version 5.12 (042293)

3261 INTERFACE CONNECTOR WIRING

PORT A - SSI CONNECTOR TO CLUSTER CONTROLLER

8 PIN RJ45 MODULAR	FUNCTION
1 > _____	ITD (N) NORMAL SSI INPUT TO 3261
2 > _____	ITD (I) INVERTED SSI INPUT TO 3261
3 > _____	ITC (N) NORMAL SSI OUTPUT FROM 3261
6 > _____	ITC (I) INVERTED SSI OUTPUT FROM 3261

PORT B - SSI CONNECTOR TO MODEL 40 TYPE SSI PRINTER (VERSION 6.07 AND LATER)

8 PIN RJ45 MODULAR	FUNCTION
1 > _____	ITC (N) NORMAL SSI OUTPUT FROM 3261
2 > _____	ITC (I) INVERTED SSI OUTPUT FROM 3261
3 > _____	ITD (N) NORMAL SSI INPUT TO 3261
6 > _____	ITD (I) INVERTED SSI INPUT TO 3261

3261 RS232C CONNECTOR TO PRINTER WIRING (CONFIGURED AS A DCE - SEE FIG. 3)

DB 25 PIN NO.	FUNCTION
1 > _____	FRAME
2 > _____	SEND DATA (PRINTER XON/XOFF FLOW CONTROL INPUT OPTION)
3 > _____	RECEIVE DATA (OUTPUT)
4 > _____	REQUEST TO SEND (PRINTER READY INPUT OPTION)
5 > _____	CLEAR TO SEND (+V OUTPUT)
6 > _____	DATA SET READY (+V OUTPUT)
7 > _____	COMMON
8 > _____	CARRIER DETECT (+ V OUTPUT)
11 > _____	REVERSE CHANNEL (PRINTER BUSY FLOW CONTROL INPUT OPTION)
15 > _____	EXTERNAL SEND BIT TIMING ELEMENT INPUT (NOT USED)
17 > _____	EXTERNAL RECEIVE BIT TIMING ELEMENT INPUT (NOT USED)
20 > _____	DATA TERMINAL READY (PRINTER READY OR BUSY FLOW CONTROL INPUT OPTION)

3261 REAR PANEL

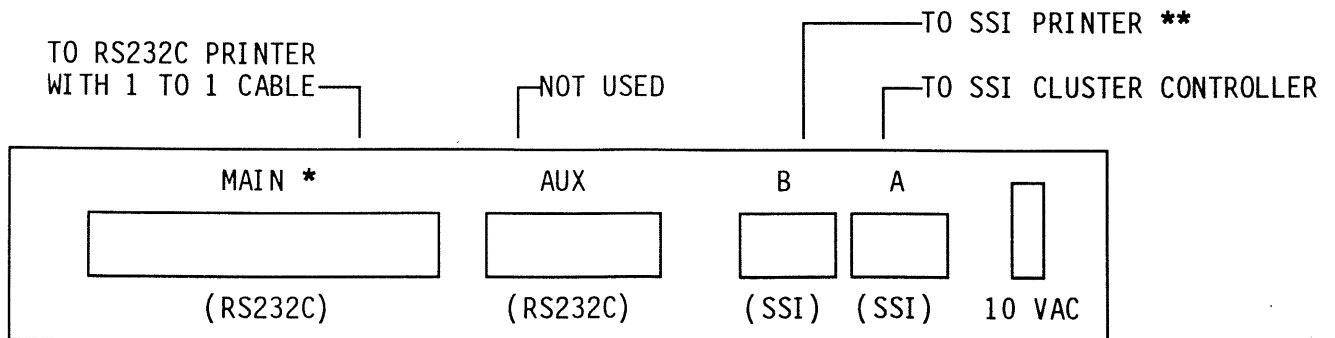

* Was marked TO MODEM on earlier units

** Later design with Version 6.07 or later

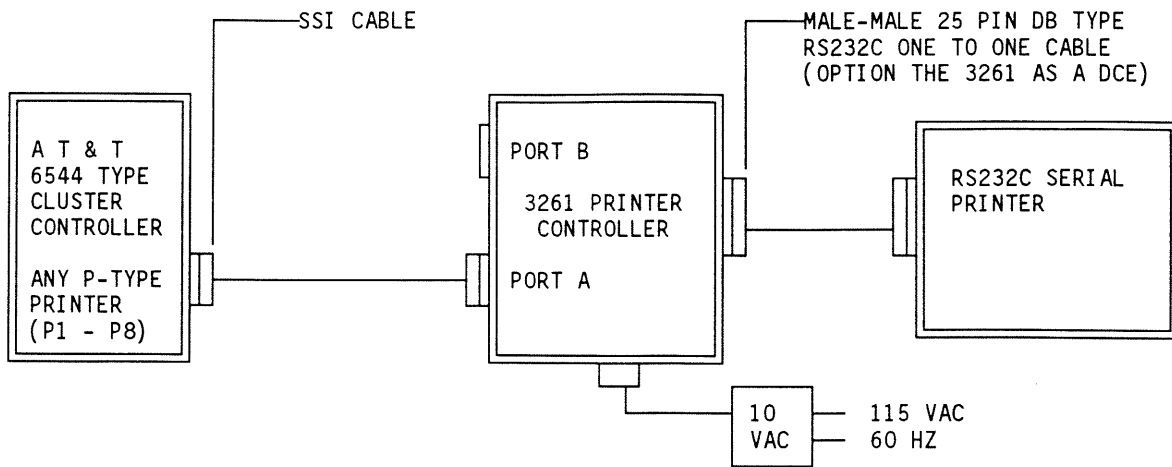
TYPICAL LOCALLY ATTACHED RS232C SERIAL PRINTER STATION ARRANGEMENT**NOTES:**

1. SSI cable is a one to one cable with RJ45 (8 PIN modular) connectors at both ends.
2. Printer cable is a male-male 25 pin DB-type one to one RS232C cable .
3. Set the 3261 Dip Switch Options and Interface Strap Options - refer to pages 7 through 10.

TYPICAL LOCALLY ATTACHED AT&T® MODEL 40/45 OR AP201 TYPE SSI PRINTER STATION ARRANGEMENT (REQUIRES VERSION 6.07 OR LATER)

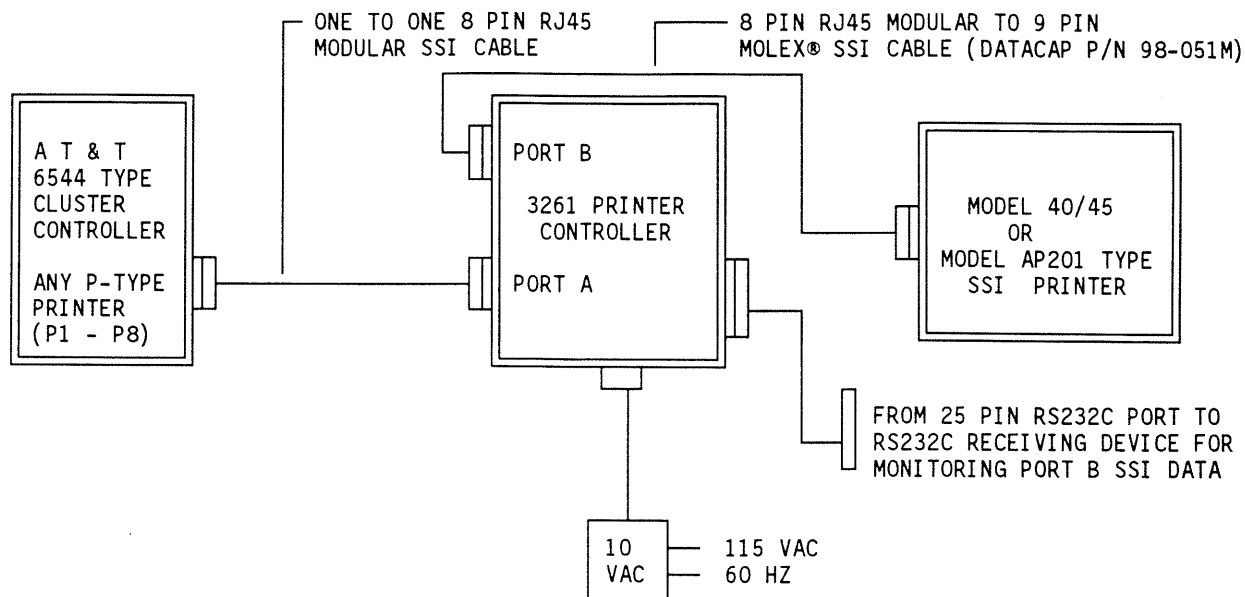

NOTES:

1. Set the 3261 Dip Protocol Switch Options to [4N] - refer to pages 7 through 10. for other options.
2. The 25 pin RS232C connector on the 3261 provides a monitoring image of the SSI printer data on Port B. The flow control is always Xon/Xoff. The Baud rate is set by OPTIONS [1A], [1B], [1C], or [1D] and the parity is set by OPTIONS [2A] or [2B].

STATION ARRANGEMENT FOR REMOTING AN RS232C SERIAL PRINTER

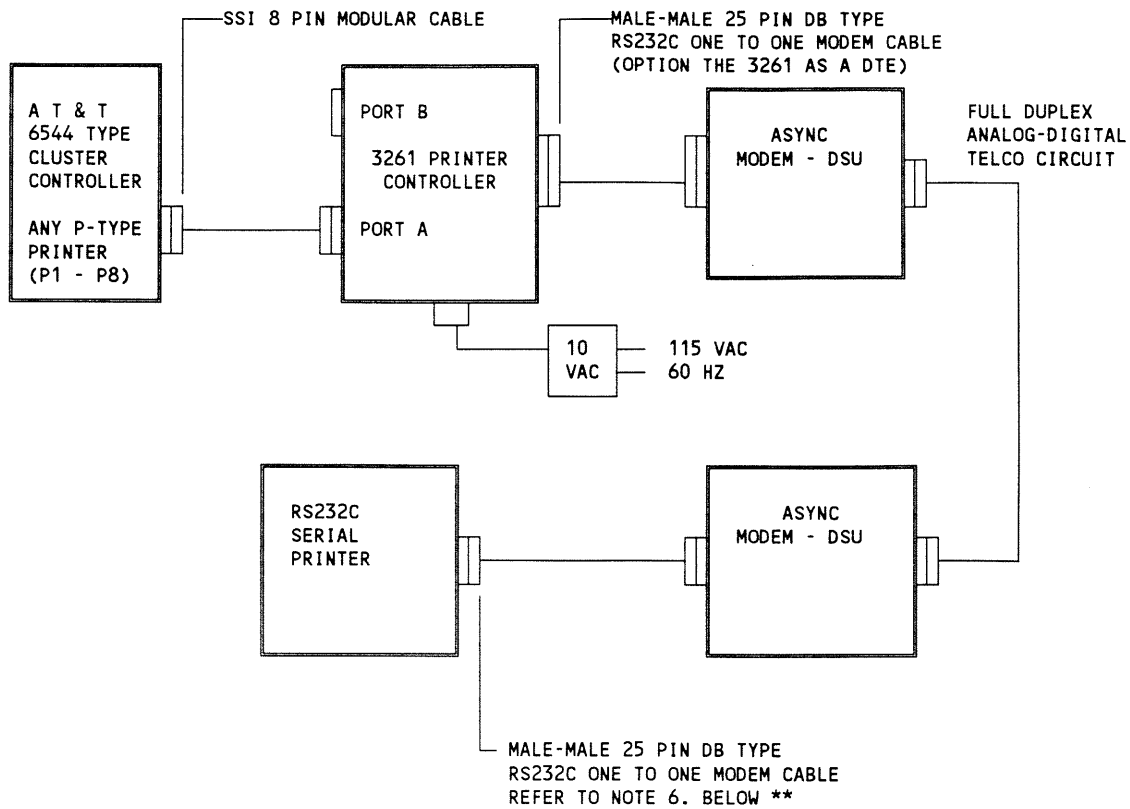

NOTES:

1. This station arrangement provides for Xon/Xoff data Flow Control and switched carrier control for printer In/Out of Service when remoting a printer over a modem - DSU network.
2. Option the 3261 for required speed OPTION [1X]), parity OPTION [2X]) and Xon/Xoff data Flow Control with DTR Out of Service OPTION [4P]. Refer to page 9.
3. Option the modem for switched carrier (RTS-pin 4 controls SEND carrier)
4. Option printer for Xon/Xoff data Flow Control with speed/parity as optioned in NOTE 2.
5. Option printer to turn off Data Terminal Ready (pin 20) and/or turn off Request to Send (pin 4) only when Out of Service or Off Line.
6. If the printer can not be optioned to turn off Request to Send when Out of Service, then wire the RS232C printer cable to tie the printer Data Terminal Ready (pin 20) to Request to Send (pin 4). **

**GENICOM 4440XT OR EQUIVALENT PRINTER STRAPPING OPTIONS
FOR USE WITH DATACAP MODEL 3261 PRINTER CONTROLLER**

- Option the DATACAP model 3261 for factory options except set the Generic Software compatibility switch options (SW2-5 and SW2-6) to match the Generic Software version that is running in the attached 6544 cluster controller.

Generic version 3.0.X - 3.3.X	SW2-5 = OFF	SW2-6 = OFF
Generic version 3.4.X	SW2-5 = ON	SW2-6 = OFF
Generic version 4.X.X or later	SW2-5 = OFF	SW2-6 = ON

- Option the Genicom 4440XT as follows -

Interface type : Serial
 Speed : 9600
 Parity : Even

Parallel Hardware straps:

0	1	2	3	4
1234567890123456789012345678901234567890123456789012345678				
010100010000000011000000111001101111100000000000				

Serial Interface straps A

0	1	2	3
123456789012345678901234567890123456789012			
00011000000000100000001000001000			

Serial Interface straps B

0	1	2	3
123456789012345678901234567890123456789012			
00000100000000000000000000000000			

Printer Control straps A

0	1	2	3
123456789012345678901234567890123456789012			
00000000010100000011000001101010			

Printer Control straps B

0	1	2	3
123456789012345678901234567890123456789012			
10000000010100000000000000000000			

NOTE: ALWAYS PERMANENTLY STORE PRINTER STRAP CHANGES

**AT&T® MODEL AP201 (460) TYPE PRINTER OPTIONS - RS232C MODE
FOR USE WITH DATAcap MODEL 3261 PRINTER CONTROLLER**

- Option the DATAcap model 3261 for factory options except set Option [4E] (Rev. Channel - pin 11 Busy Flow Control) and set the Generic Software compatibility switch options (SW2-5 and SW2-6) to match the Generic Software version that is running in the attached 6544 cluster controller.

Generic version 3.0.X - 3.3.X	SW2-5=OFF	SW2-6=OFF
Generic version 3.4.X	SW2-5=ON	SW2-6=OFF
Generic version 4.X.X or later	SW2-5=OFF	SW2-6=ON

- Option the model AP201 (460) as follows -

OPTION NUMBER

500a	9600 Baud RS232C	S1-5=S2-1=S2-2=S2-3=OFF, AND S2-7=ON
501e	Form Feed on FF	S1-6=S2-4=S2-7=ON
502b	Auto NL after 132	S1-7=S2-5=OFF, AND S1-8=ON
* 503c	ASCII font no parity	S15-4=S15-6=S2-5=OFF, AND S15-3=ON
* 503f	EBCDIC font no parity	S15-4=S15-6=OFF, AND S2-5=S15-3=ON
504a	Disable escape	S2-8=ON
505b	No expanded print	S14-3=ON
506b	No condensed print	S14-4=OFF
507a	No perforation skip	S15-1=S15-7=ON

ALSO SET

S1-1=S1-2=S1-3=S1-4=OFF
 S14-1=S14-2=S14-5=S14-6=S14-7=S14-8=OFF
 S15-2=S15-8=OFF

*** Choose 503c OR 503f**

- Use DATAcap P/N 98-061A RS232C interface cable wired as follows -

DB 25 PIN MALE		DB 50 PIN MALE
1	<----->	16 FRAME
3	<----->	22 RECEIVE DATA
4	<----->	23 RTS
5	<----->	9 CTS
6	<----->	6 DSR
7	<----->	39 COMMON
8	<----->	8 CARRIER
11	<----->	20 PRINTER BUSY
20	<----->	7 DTR

WARNING: THIS EQUIPMENT GENERATES, USES, AND CAN RADIATE RADIO FREQUENCY ENERGY AND IF NOT INSTALLED AND USED IN ACCORDANCE WITH THE INSTRUCTION MANUALS, MAY CAUSE INTERFERENCE TO RADIO COMMUNICATIONS. IT HAS BEEN TESTED AND FOUND TO COMPLY WITH THE LIMITS FOR A CLASS A COMPUTING DEVICE PURSUANT TO SUBPART J OF PART 15 OF FCC RULES, WHICH ARE DESIGNATED TO PROVIDE REASONABLE PROTECTION AGAINST SUCH INTERFERENCE WHEN OPERATED IN A COMMERCIAL ENVIRONMENT. OPERATION OF THIS EQUIPMENT IN A RESIDENTIAL AREA IS LIKELY TO CAUSE INTERFERENCE IN WHICH CASE THE USER AT HIS OWN EXPENSE WILL BE REQUIRED TO TAKE WHATEVER MEASURES MAY BE REQUIRED TO CORRECT THE INTERFERENCE.

IMPORTANT NOTES FOR DATACAP 3261 VERSION 5.09 OR LATER

1. VERSION 5.09 OR LATER ADDS THE SINGLE BYTE TRANSPARENT DEVICE ORDER (35 HEX) UNDER SNA-LU1 OPERATION. TO SEND ANY SINGLE 8 BIT BYTE TO THE PRINTER, SEND THE SEQUENCE 35 HEX - 01 HEX IN FRONT OF THE ANY 8 BIT BYTE TO BE SENT TO THE PRINTER ATTACHED TO THE DATACAP 3261.
2. VERSION 5.12 OR LATER ADDS THE EBCDIC ESCAPE CHARACTER OPTION - WHEN ACTIVATED (SW2-7 = ON), AN EBCDIC CENTS SIGN (HEX 4A) FROM THE HOST PRINTS AS AN ASCII ESCAPE (HEX 1B). THIS FEATURE SIMPLIFIES SENDING ESCAPE SEQUENCES TO THE PRINTER.
3. VERSION 6.07 ADDS MODEL 40/45 OR AP201 SSI PRINTER SUPPORT WITH SIMULTANEOUS RS232C MONITORING OUTPUT. THE 3261 HARDWARE MUST BE THE LATER DESIGN WITH THE FOUR SSI INTERFACE TRANSFORMERS INSTALLED. THE SSI PRINTER OUTPUT IS AT PORT B. TO ACTIVATE THE SSI PRINTER PORT, SET SWITCHES SW1-6 = OFF, SW1-7 = ON AND SW1-8 = ON. SEE MANUAL PAGE 9 FOR FURTHER DETAILS.
4. YOU MUST ALWAYS SET THE 3261 GENERIC SOFTWARE COMPATIBILITY SWITCH OPTIONS TO MATCH THE 6544 CLUSTER CONTROLLER GENERIC SOFTWARE VERSION -

3261 SWITCH POSITIONS		6544 SOFTWARE VERSION
SW2-5	SW2-6	
OFF	OFF	GENERIC 3.0.X THROUGH 3.3.X
ON	OFF	GENERIC 3.4.X
OFF	ON	GENERIC 4.X.X OR LATER (INCLUDING 5.X.X)